

MTX•LS

PORTABLE RADIOS

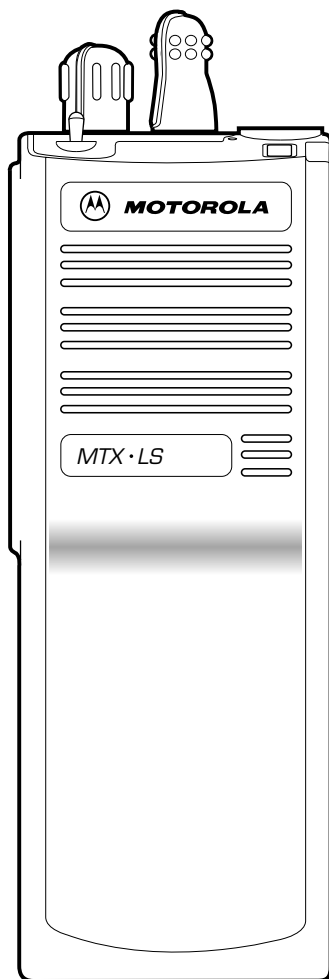

MOTOROLA

Operating
Instructions

68P81083C35-X

Contents



Warnings, Cautions, and Notes	3
Computer Software Copyrights	4
1 - Product Introduction	5
Standard Features and Benefits	6
Radio Feature Programming	7
Advantages Of Trunking	8
2 - Getting Started	9
Radio/Antenna Identification	9
Antenna Installation	10
Battery Installation	11
Battery Removal	11
Universal Connector Seal Removal	12
Belt Clip Installation and Removal (on Nickel-Cadmium Batteries Only)	13
Installing the Belt Clip	13
Removing The Belt Clip	14
3 - Quick Reference	15
Controls, Switches, Indicators, and Connectors	15
Tones	17
4 - Basic Operation	19
Turning the Radio On	19
Receiving	19
Trunked Modes and Conventional Channels	19
Call Light (Trunking Only)	20

Ⓜ, Motorola, MTX•LS, and Call Alert are trademarks of Motorola, Inc.
LTR® is a registered trademark of the E. F. Johnson Company.

© 1995 by Motorola, Inc.
Radio Products Group
8000 West Sunrise Blvd.
Ft. Lauderdale, FL 33322

Printed in U.S.A
All Rights Reserved.

Monitoring a Conventional Channel	20
Transmitting on a Trunked System	20
Transmitting on a Conventional Channel	21
Smart PTT	21
5 - Telephone Interconnect	23
To Receive A Telephone Call	23
6 - Scan	25
Types of Scan	25
Auto Group Scan	25
All Group Scan	26
Mode Slaved Scan	26
Deleting Nuisance Modes	26
7 - Battery Information	27
Recharging Nickel-Cadmium Batteries	27
Charging Temperature	27
Short Circuit	28
Memory Effect (Reduced Charge Capacity)	28
Battery Disposal	28
Nickel-Cadmium Battery Recycling Facility	30
8 - Optional Accessories	31
9 - Safety Information	35
Safety Standards	35
Restrictions	37
Airbag Warning Statement	38
10 - General Information	39
Radio Care	39
Cleaning	39
Handling	39
Service	40
Radio Checks	40
Operating Instructions	41
Problem(s) Not Solved	41
Express Service Plus (ESP), U.S.A. only	41
Parts Information	42
11 - Glossary	43

Warnings, Cautions, and Notes

Throughout this publication, you will notice the use of WARNINGS, CAUTIONS, and Notes. These notations are used to emphasize that safety hazards exist, and care must be taken or observed.

 WARNING	An operational procedure, practice, or condition, etc., which may result in injury or death if not carefully observed.
---	---

 Caution	An operational procedure, practice, or condition, etc., which may result in damage to the equipment if not carefully observed.
---	--

Note: An operational procedure, practice, or condition, etc., which is important to emphasize.

Computer Software Copyrights

The Motorola products described in this instruction manual include copyrighted Motorola computer programs stored in semiconductor memories or other mediums. Laws in the United States and other countries preserve for Motorola certain exclusive rights for copyrighted computer programs, including the exclusive right to copy or reproduce in any form a copyrighted computer program. Accordingly, any copyrighted Motorola computer programs contained in the Motorola products described in this instruction manual may not be copied or reproduced in any manner without the express written permission of Motorola. Furthermore, the purchase of Motorola products shall not be deemed to grant either directly or by implication, estoppel or otherwise, any license under the copyrights, patents, or patent applications of Motorola, except for the normal nonexclusive, royalty fee license to use that arises by operation of law in the sale of a product.

Product Introduction

Welcome to the MTX•LS™ Trunked Portable Radio Family. Your choice of the Motorola MTX•LS means you have selected the highest of standards in design, quality, and performance.

The MTX•LS radio gives you the flexibility to operate on both conventional repeater systems and the popular, LTR® trunking system. The radio supports up to 14 trunking systems, which lets you maintain communications while roaming from area to area. The radio also supports up to 10 conventional channels, which gives you the freedom to switch to a conventional repeater or to communicate directly with other two-way radios.

Inspect the shipping carton for any signs of damage. Remove and check the contents to be sure that all ordered items have been shipped. If items have been damaged during transit, report the damage to the shipping company immediately.

Radio Packing Box Contents:

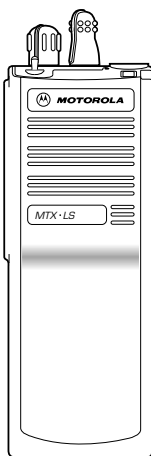

- ◆ Radio
- ◆ Antenna
- ◆ Battery
- ◆ Belt Clip
- ◆ Operating Instructions Manual
- ◆ Universal Connector Seal

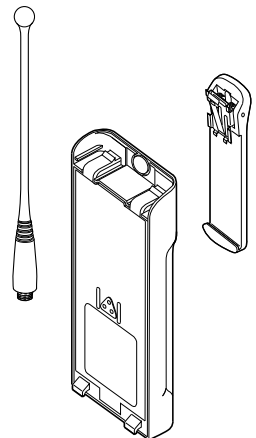

Standard Features and Benefits

The following features are standard with the MTX•LS radio.

LTR trunked operation

- ◆ 14 systems
- ◆ 3 groups per system
- ◆ Fast system access
- ◆ Automatic retry
- ◆ Flexible group structuring
- ◆ Priority Scan
- ◆ Telephone interconnect allows you to receive telephone calls through a properly-equipped trunking system
- ◆ Transmit Inhibit
- ◆ Call Light

Conventional operation

- ◆ 10 channels
- ◆ Talkaround operation lets you bypass repeaters
- ◆ Priority Scan
- ◆ Smart PTT keeps radio users from transmitting on an active channel
- ◆ Receive Only
- ◆ Private-Line® (PL) Subaudible Signalling

Ergonomic design

- ◆ Comfortable, light weight, rugged, hand-held portable unit
- ◆ Easily accessible controls
- ◆ Remote accessory capability

- ◆ Dual-height, contoured knobs
- ◆ Nuisance Delete of scan list members
- ◆ Single, top-mounted toggle switch

Ease of operation

- ◆ Scan function allows the radio to automatically scan across any combination of 16 modes
- ◆ Time-Out Timer automatically shuts off transmitter after a programmable amount of transmission time

Rugged, dependable design

- ◆ Designed to MIL-STD 810 C, D and E for shock and vibration, the toughest environmental test for a portable radio
- ◆ 3-Watt power output
- ◆ $\pm 0.00025\%$ frequency stability
- ◆ Power-up check validates correct operation each time the radio is turned on

Radio Feature Programming

The following features of your radio can be programmed by your dealer:

- ◆ Conventional and trunked frequencies
- ◆ Trunked modes and groups
- ◆ Squelch
- ◆ Tone Private-Line (TPL) codes
- ◆ Digital Private-Line® (DPL) codes
- ◆ Transmit Time-Out Timer
- ◆ Scan list
- ◆ Smart PTT

- ◆ Radio Self Check Feedback
- ◆ Permanent Monitor
- ◆ Call Light
- ◆ Transmit Inhibit
- ◆ Talk Permit tone

Advantages Of Trunking

Trunking allows many users to share a fixed number of communication channels without interfering with one another. Telephone companies for years have used trunking to make the most efficient use of their equipment, and similar trunking methods have been adapted to two-way radio communication.

A trunked radio system allows a large number of users to share a relatively small number of frequencies. When an operator establishes communication with someone else in the system, the system automatically assigns a communication path - a repeater and its frequency. Once the conversation has ended, the repeater is freed for other users. Trunking pools all the repeater air time, and this maximizes the amount of air time available to any one mobile unit and minimizes channel congestion.

Some of the key benefits of trunked two-way radio systems are:

- ◆ No channel monitoring required prior to transmission
- ◆ Fast system access
- ◆ Automatic channel selection
- ◆ Privacy among members of the same group

Getting Started

Radio/Antenna Identification

An information label is attached to the back of your radio (chassis), just under the battery contacts. A radio model number is shown on this label. A typical model number might be H01UCC6DU3AN. The fourth position of the model number (in this case “U”) identifies the operating frequency band of the radio. Table 1 lists all fourth-position alpha characters and corresponding frequency band.

Table 1 Radio Operating Frequency

Fourth-Position Character	Frequency Band
U	806-870MHz
W	896-941MHz

Antennas are frequency sensitive and are color coded according to the frequency range of the antenna. The color code indicator is the insulator in the center of the base of the antenna. The illustrations and Antenna Identification Chart (page 10) will help identify the antenna, antenna frequency range, and corresponding color code.

Refer to Table 1, “Radio Operating Frequency,” on page 9 and Table 2, “Antenna Identification Chart,” on page 10 to ensure that the match between your radio and antenna is correct.

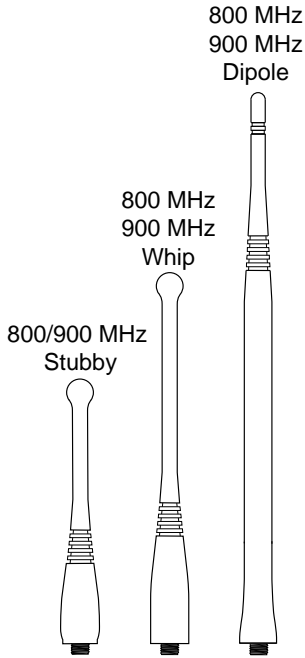

Table 2 Antenna Identification Chart

Antenna Type	Approximate Length		Insulator Color Code	Frequency Range
	In.	MM.		
800/900 MHz Stubby, Quarterwave	3.3	83	WHITE	806-941MHz
800MHz Dipole	8	200	RED	806-870MHz
900MHz Dipole	8	200	BLUE	896-941MHz
800MHz Whip	7	175	RED	806-870MHz
900MHz Whip	6.6	165	BLUE	896-941MHz

Antenna Installation

Screw the threaded end of the antenna into the antenna receptacle located on top of the radio. Rotate the antenna clockwise until it fits firmly against the bushing.

Battery Installation

1. Turn off the radio and hold it with the back of the radio facing up.
2. Place the two tabs of the battery (located at the inside base of the battery) into the metal cutouts of the radio (located at the inside base of the radio).
3. Rotate the battery toward the radio and press the top of the battery into the radio until both battery release levers “click” into place.

NOTE: The battery is shipped uncharged. Batteries must be charged before use. (See Battery Information section.)

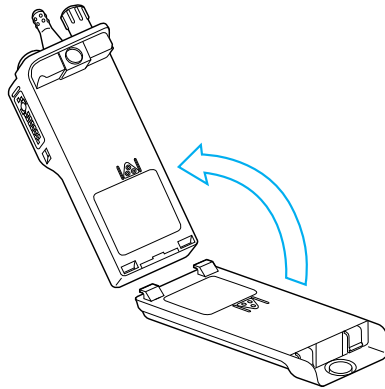

Battery Removal

1. Turn off the radio and hold it such that the battery side of the radio is tilted down.
2. Press down on the two battery release levers.
3. With release levers pulled down, the top of the battery will fall away from the radio.
4. Remove the battery from the radio.

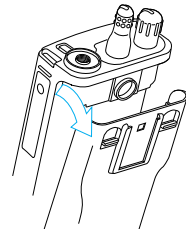
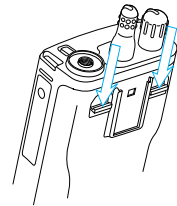

Universal Connector Seal Removal



Caution

When not in use, keep the side connector covered using the universal connector seal provided.

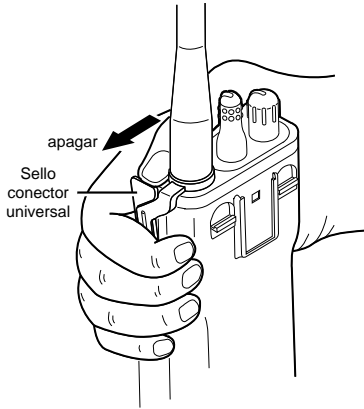

If the universal connector seal is attached to the radio:

1. Turn the radio off when removing the seal.
2. Grasp the radio as illustrated, and push your thumb against the tabbed portion of the seal with enough force to unsnap the universal connector seal from the radio.
3. Rotate the seal around the antenna to move it away from the universal connector; slide the seal off of the antenna and completely away from the radio.

Belt Clip Installation and Removal (on Nickel-Cadmium Batteries Only)



Caution

Installation and removal of the belt clip assembly should be done with the battery removed from the radio or damage could be done to the radio housing.

Installing the Belt Clip

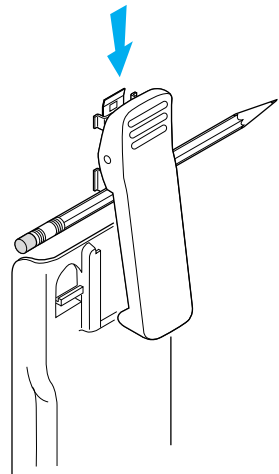
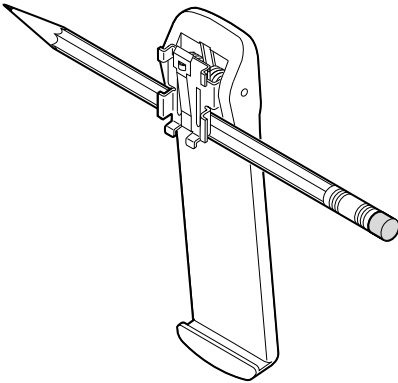

1. Insert a pencil or equivalent size instrument between the inside of the belt clip and the metal clip assembly to hold the metal clip partially sprung (metal clip should be approximately parallel with the plastic portion of the belt clip).
2. Align the metal tabs of the belt clip with the plastic slots of the battery housing.
3. Slide the belt clip onto the battery, pushing firmly until you hear a click.
4. Remove the pencil from the clip.

Removing The Belt Clip

1. Insert a pencil or equivalent size instrument between the inside of the belt clip and the metal clip assembly to hold the metal clip partially sprung (metal clip should be approximately parallel with the plastic portion of the belt clip).

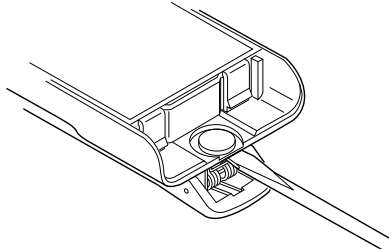

2. Push the flat blade of a #2 slotted screwdriver (or like instrument) between the battery housing and the belt clip release tab.
3. While performing step 2, slide the belt clip out and away from the battery, and remove the screwdriver.
4. Remove the pencil from the clip.

Quick Reference

Controls, Switches, Indicators, and Connectors

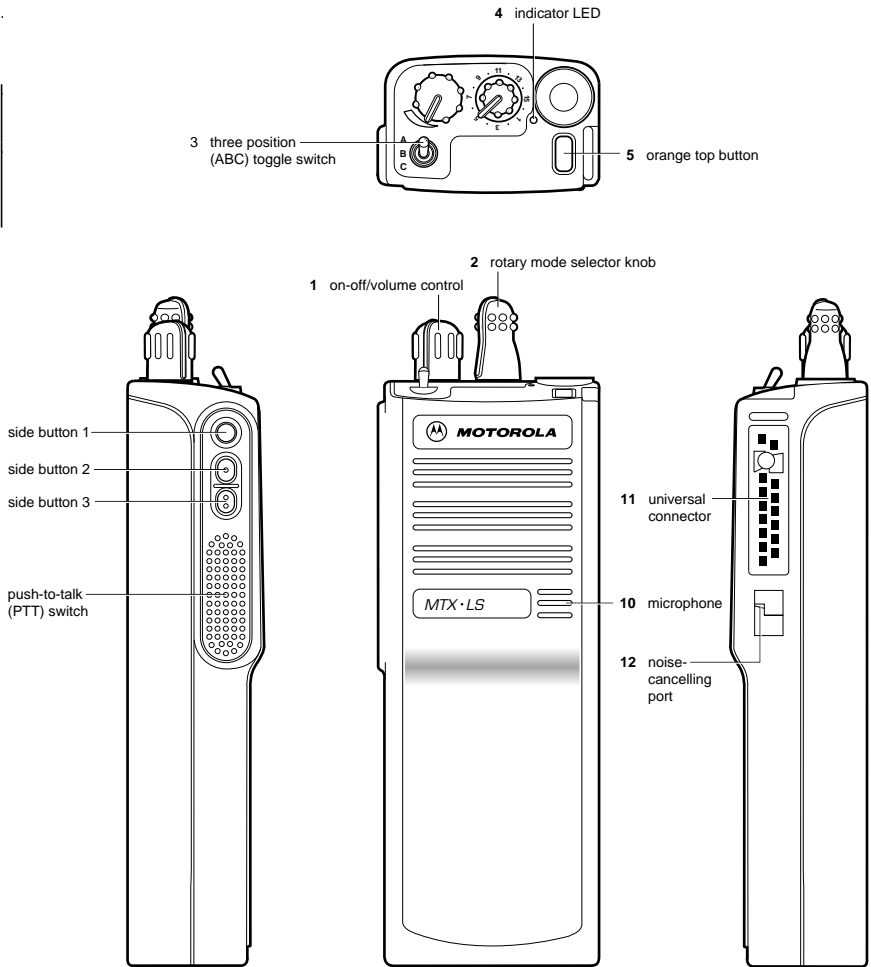

1 ON/OFF/ VOLUME CONTROL

Turns the radio on or off and adjusts the volume level.

2 ROTARY MODE SELECTOR KNOB (16-Position)

Allows you to select conventional and trunking modes.

3 THREE-POSITION (A B C) TOGGLE SWITCH

Allows you to select the radio LTR operating group or conventional channel.

4 LED INDICATOR

Indicates the radio's operating status; green/red/yellow light-emitting diode (LED). (See "Indicator LED Indications" paragraph.)

5 ORANGE TOP BUTTON

For future use.

6 SIDE BUTTON 1

Programmed at shipment for scan on/off function.

7 SIDE BUTTON 2

Programmed at shipment for "deleting nuisance modes."

8 SIDE BUTTON 3

Programmed at shipment for monitor operation.

9 PUSH-TO-TALK (PTT) SWITCH

Puts the radio in the transmit mode.

10 MICROPHONE PORT

Accepts voice input to the radio's microphone.

11 UNIVERSAL CONNECTOR

Provides access for programming, testing, and accessory connections.

12 NOISE-CANCELLING PORT

Reduces background noise during transmit.

Tones

The following table lists MTX•LS radio signal names, their tones, and their meanings.

Table 3 MTX•LS Signals

If you hear...	It means that...	Take this action...
<p>TALK PERMIT TONE A high-pitched <i>dit-dit-dit</i> tone after the PTT is pressed</p>	You made a successful attempt to access the trunked system.	Proceed with conversation.
<p>TALK PROHIBIT TONE A continuous <i>baaah</i> tone when PTT is pressed</p>	The conventional Smart PTT function prohibited you from transmitting.	Try again when channel is clear.
<p>TRANSMIT INHIBIT TONE A continuous <i>baaah</i> tone when PTT is pressed</p>	You attempted to transmit after receiving a Transmit Inhibit ID (LTR only).	Release PTT, wait three seconds, and try again.
<p>OUT OF RANGE TONE A continuous <i>baaah</i> tone when the PTT is pressed</p>	You made an unsuccessful attempt to access the trunked system. Normally this occurs when the radio is out of range.	Try again when you are in a better location, for example, when on a hill or closer to the system.
	The system is out of service.	Wait until the system is back in operation and try again.
<p>BUSY TONE A continuous <i>bah bah bah</i> tone when the PTT is pressed</p>	All available channels are busy, or the radio is continuously trying to access the trunking system.	Release the PTT switch and try again a few moments later, or hold the PTT until you get access.

Table 3 MTX•LS Signals

If you hear...	It means that...	Take this action...
VALID KEY TONE A high-pitched <i>chirp</i> when a button is pressed	The button press was accepted.	Proceed with desired function.
INVALID KEY TONE A <i>bonk</i> tone when a button is pressed	You pressed an illegal button for the current operation.	Select another function.
TIME-OUT TIMER WARNING TONE A <i>bonk</i> tone while transmitting	The present transmission will end in four seconds.	Finish your transmission before your transmitter is disabled.
TIME-OUT TIMER TONE A continuous <i>baah</i> tone when the PTT is pressed	The transmission has ended.	Release PTT.
LOW-BATTERY TONE A <i>cricket chirp</i> tone on PTT release or periodically in stand-by	The battery is getting low on charge.	Charge the battery or replace the battery with a charged battery.
PRIORITY MODE RECEIVE TONE A high-pitched <i>chirp</i>	A priority mode was received during scan.	Listen to the priority call.

Basic Operation

Turning the Radio On

1. Turn the on/off/volume control clockwise until it clicks. You will hear a *chirp* tone after a successful power-up.

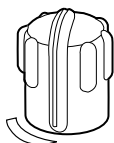

On/Off
Volume Control

NOTE: Each time it is turned on, the radio performs a self check to validate correct operation. If the radio is not operating at the exact parameters set in the factory or field, you will hear a 5-second warning tone instead of the normal *chirp* tone. This indicates the radio should be serviced immediately.

2. The unit automatically operates dependant on current switch settings. Set the volume by turning the on/off/volume control clockwise. One half turn equals about 50% output.

Receiving

Trunked Modes and Conventional Channels

1. Turn the radio on and select the desired mode and group for trunking, or desired mode and channel for conventional.
2. Listen until you hear a transmission, then adjust the volume control for a comfortable listening level.
3. Your radio is now set to receive calls on the selected mode.

NOTE: If the mode selector knob and the 3-position toggle switch are both placed on an unprogrammed position (blank position), you will hear an “invalid

mode” tone until the mode selector knob and 3-position toggle switch select a programmed (valid) position.

NOTE: If the channel is busy during conventional operation, the radio’s red LED will blink in receive operation.

NOTE: The red LED will blink if a low-battery condition occurs during transmit operation.

Call Light (Trunking Only)

If this feature is enabled on a group or a universal ID that is received, then the green LED will blink. To turn off the call light, change the group or mode, press the PTT, or press any valid button.

Monitoring a Conventional Channel

1. To unscquelch the radio while on a conventional channel, press side button 3. This unmutes the speaker (if open squelch monitor is programmed using RSS). You may then adjust the volume with the on/off/volume control.
2. To place the radio in the permanent monitor mode, press and hold side button 3 for approximately 2.5 seconds (time programmable using RSS). The radio emits a brief high-pitched tone as it enters the permanent monitor mode. To return the radio to its original squelch state, one of the following can be done: press side button 3 again, press the PTT (Push To Talk) switch, change modes or channels, or turn the radio off and on.

Transmitting on a Trunked System

1. Press the PTT switch.
2. If the *dit-dit-dit* talk permit tones (programmed using RSS) are heard, continue to push the PTT switch and speak into the microphone in a normal voice. The red LED indicator will stay

on continuously to indicate that you are “on the air.”

3. If you hear other tone(s) when you push the PTT switch, the radio is alerting you that certain system conditions exist. Refer to Table 3, “MTX•LS Signals,” on page 17.
4. If your radio has the Time-Out-Timer function activated, transmission will terminate if you hold down the PTT switch for more than a preprogrammed time period (programmed using RSS). When time-out occurs, a *bonk* alert tone sounds 4 seconds before the transmission is terminated. If the PTT switch is not released within 4 seconds, the radio stops transmitting and a continuous alert tone is generated until the PTT switch is released. To resume transmitting, release the PTT switch and push again.

Transmitting on a Conventional Channel

1. The red LED indicator will flash if there is another unit active on the channel. Do not transmit if anyone else is using the channel.
2. When you press the PTT, the red LED indicator will stay on continuously to indicate that you are “on the air.” If you hear tone(s) when you push the PTT switch, the radio is alerting you that certain system conditions exist. Refer to Table 3, “MTX•LS Signals,” on page 17.
3. If your radio has the Time-Out-Timer function activated, transmission will terminate if you hold down the PTT button for more than a preprogrammed time period (programmed using RSS). When time-out occurs, a *bonk* alert tone sounds 4 seconds before the transmission is cut. If the PTT switch is not released within 4 seconds, the radio stops transmitting and a continuous alert tone is generated until the PTT switch is released. To resume transmitting, release the PTT switch and push again.

Smart PTT

Smart PTT is a per-channel feature which gives the system manager better control of radio operations. When smart PTT is activated in your radio (using RSS), the user will not be able to transmit on

an active channel. Three radio-wide variations of smart PTT are available:

1. **Transmit Inhibit on Busy Channel:** With this feature enabled, you will be inhibited from transmitting if any activity is detected on the channel.
2. **Transmit Inhibit on Busy Channel with Wrong Squelch Code:** With this feature enabled, you will be inhibited from transmitting on an active channel with a squelch code other than your own. If the squelch code is the same as yours, the transmission will not be inhibited.
3. **Quick-Key Override:** This feature can work in conjunction with variation one or two. With this feature enabled, you will be able to override the transmit inhibit state by quick-keying (two PTT activations within one second of each other) the radio.

Smart PTT radio operation is exactly the same as standard radio operation, except that if you try to transmit (press PTT) on a Smart PTT channel, a continuous alert tone is generated until the PTT is released; the transmission is inhibited.

Telephone Interconnect

5

Your MTX•LS radio is equipped with Telephone Interconnect, which allows you to receive calls from landline telephones through the trunking system central computer. Calls from the landline user can be private or can include a whole group.

Keep in mind that a radio operator can either talk or listen at one time, whereas the landline user has duplex (talk and listen) operation. This means a radio operator who is speaking will not hear an interruption from the landline user. Therefore, the landline user should be warned to listen for a beep (system dependent) before speaking.

To Receive A Telephone Call

1. To make a call to the radio, the landline party will dial an interconnect terminal phone number. If the system is busy, the landline party hears a normal busy signal, and must hang up and try again. If the phone line is open, the caller will hear a tone (system dependent). The caller should then enter the access code assigned to the desired radio unit. Both the landline and the radio user will hear a ringing tone.
2. To answer, press the PTT and begin talking.
3. Keep these points in mind during your conversation:
 - ◇ The landline user should be informed that you are using a radio and that replies should be made only after you have finished transmitting. The landline user will hear a soft *beep* (system dependent) after you release the PTT switch. Explain that only one person can talk at a time.
 - ◇ If the landline user speaks while you are transmitting, you will not hear them. Proceed with the conversation in a normal two-way radio manner by pushing the PTT switch

to transmit and releasing the PTT switch to listen.

NOTE: During phone, several users may share the same ID. Therefore, courtesy must be used when answering a call or during a phone conversation since multiple users can respond simultaneously.

4. To disconnect the call and return to dispatch operation, the call will be terminated by the landline user or by the system time-out timer.

Scan

6

Scan is a feature that allows your MTX•LS portable radio to search for, lock onto, and monitor activity on conventional channels or trunked groups. For mode slaved scan, as many as sixteen modes can be RSS programmed, which may include up to 14 trunked modes or up to 10 conventional channels.

Three types of scan are available, Auto Group Scan, All Group Scan, and Mode Slaved Scan. Auto Group Scan and All Group Scan are LTR trunking features. Mode Slaved Scan is a trunking and conventional scan feature. All of the scan features in this radio are programmed using RSS, and are not front panel programmable.

Types of Scan

Auto Group Scan

In Auto Group Scan, only certain groups within the selected mode (programmed via RSS) will be scanned. If a group is programmed for this feature, scanning begins when that group is selected.

NOTE: The 16-position switch must be set to a trunking mode, and the three-position toggle switch placed in a position with scan enabled (either A, B, and/or C) for scanning to begin.



3-Position
Toggle Switch



16-Position Switch

All Group Scan

In All Group Scan, all groups within the mode (selected via the 16-position switch) will be scanned. If the mode selected is programmed with this feature, scanning begins with a long press (approximately 1.5 seconds - RSS programmable) of side button 1. During All Group Scan, the LED double-blinks yellow. Exit scan by changing modes, by a momentary press of side button 1, or by turning the radio off.

Mode Slaved Scan

With this feature, a scan list is programmed directly to a mode (selected by the 16-position switch). Scanning begins with a short (momentary) press and release of side button 1. During Mode Slaved Scan, the LED blinks yellow. Exit scan by changing modes, by a momentary press of side button 1, or by turning the radio off.

NOTE: An MTX•LS radio, Mode Slaved Scan, can be RSS programmed per mode for priority and non-priority scan. Priority modes in the list are scanned more often than non-priority modes in the list.

Deleting Nuisance Modes

When the radio scans to a mode that you do not wish to hear (nuisance mode), you can temporarily delete the mode from the scan list.

1. When the radio is locked onto the mode to be deleted, press the nuisance mode delete button, side button 2. A valid key tone is heard, indicating that the mode has been deleted. Neither the priority mode nor the selected mode may be deleted from the scan list.
2. The radio continues scanning the remaining modes in the list. To resume scanning the deleted mode, you must exit and reenter scan operation.

Battery Information

7

The MTX•LS radio receives its power from a rechargeable nickel-cadmium (NiCd) battery as listed in the accessories section. These batteries are a safe, dependable power source for your radio. Proper care of the battery will ensure its effectiveness and allow for peak radio performance.

Recharging Nickel-Cadmium Batteries

Recharge the battery before use to ensure optimum capacity and performance. The battery was designed specifically to be used with a Motorola charger. Charging in non-Motorola equipment may lead to battery damage and void the battery warranty.

NOTE: Note: When charging a battery that is attached to the radio, turn the radio off to ensure a full charge.



Do not attempt to change or charge the battery in a hazardous atmosphere. See Safety Standards section of this manual.

Charging Temperature

The battery should be at room temperature (about 77°) whenever possible. Charging a cold battery (below 50° F) may result in leakage of electrolyte and ultimately, in failure of the battery. Charging a hot battery (above 95° F) results in reduced discharge capacity, affecting the performance of the radio. MTX•LS rapid-rate battery chargers contain a temperature-sensing circuit to ensure that the battery is charged within these temperature limits.

Short Circuit

Care should be taken to avoid external short-circuiting of the battery.

 WARNING	A sustained high-rate discharge (for example, a paper clip placed accidentally across the battery contacts) may permanently damage the battery, void the battery warranty, and create a burn or fire hazard.
---	---

Memory Effect (Reduced Charge Capacity)

Memory effect is a phenomenon which causes a temporary loss in battery capacity or voltage due to repetitive shallow discharging or long-term overcharging. This memory effect has been virtually eliminated from Motorola batteries through the use of new cell technology.

Battery Disposal



For disposal, nickel-cadmium sealed rechargeable batteries should be delivered to an authorized metals-reclamation dealer.

 WARNING	Do not dispose of any batteries in a fire as they may explode!
---	---

This product is powered by a nickel-cadmium rechargeable battery. At the end of its useful life, the battery can be recycled. However, recycling facilities may not be available in all areas. Under various state or local laws, the battery must be recycled or disposed of properly, and cannot be disposed of in landfills or incinerators. In addition, U.S. Environmental Protection Agency (EPA) regulations classify used nickel-cadmium batteries as hazardous waste, unless certain exemptions apply.

Motorola fully endorses and encourages the recycling of nickel-cadmium batteries. If you are located in the United States, you can ship, postpaid, your used Motorola nickel-cadmium batteries to INMETCO, an EPA-approved recycling facility at the address given on the next page. We recommend used batteries be sent to the nickel-cadmium recycling facility. Should you have any questions, contact the facility first.

Consideration should be given to the methods of collecting, labeling, and shipping used nickel-cadmium batteries. Your federal, state, or local EPA should be consulted for specific requirements and for recycling options in your area.

Motorola, as a responsible corporate citizen, has always been concerned with the protection of the environment. For further information, you may call the Motorola America's Parts Division, Customer Service Department, toll-free at 1-800-422-4210.

Nickel-Cadmium Battery Recycling Facility

INMETCO, Bin # M1
P.O. Box 7202
245 Portersville Road
Ellwood City, PA 16117
Phone: (412) 758-2800
Fax: (412) 758-9311

For additional information, write to:
Motorola
Energy Products Division
Customer Care Department
1700 Belle Meade Court
Lawrenceville, GA 30243-5854

Optional Accessories

Motorola offers several accessories to increase communications efficiency. Many of the accessories are listed. Contact your Motorola dealer for other accessories that apply to your MTX•LS radio and your particular needs.

Antennas

- NAF5037 *Whip (800MHz)
- NAF5038 *Whip (900MHz)
- NAF5039 *Dipole (800MHz)
- NAF5040 *Dipole (900MHz)
- NAF5042 *Quarter Wave, Stubby (800MHz, 900MHz)

Batteries

- NTN7143 High-Capacity Nickel-Cadmium (Non-incentive, groups A, B, C, D)
- NTN7144 Ultra-High-Capacity Nickel-Cadmium (Non-incentive, groups A, B, C, D)
- NTN7146 *High-Capacity Nickel-Cadmium FMRC Intrinsically Safe (groups D, F, G)
- NTN7147 *Ultra-High-Capacity Nickel-Cadmium FMRC Intrinsically Safe (groups D, F, G)
- NTN7341 *High-Capacity Nickel-Cadmium FMRC Intrinsically Safe (groups C, D, E, F, G)
- NTN7372 *Ultra-High-Capacity Nickel-Cadmium FMRC Intrinsically Safe (groups C, D, E, F, G)

Battery Chargers

Single-Unit Slow-Charge, 50/60Hz Desk-Top:

- NTN1174 117Vac, with 117Vac Wall-Mount Transformer
- NTN1175 220Vac with International Wall-Mount Transformer
- NTN1176 240Vac with International Wall-Mount Transformer

Single-Unit Rapid-Charge, 50/60Hz Desk-Top:

- NTN1171 117Vac, with 117Vac Cord and Plug
- NTN1172 220Vac with International 220Vac Cord and Plug
- NTN1173 240Vac with International 240Vac Cord and Plug

Single-Unit Dual-Rate Battery Chargers, 50/60Hz Desk-Top:

- NTN1168 117Vac with 117Vac Cord and Plug
- NTN1169 220Vac with International 220Vac Cord and Plug
- NTN1170 240Vac with International 240Vac Cord and Plug

Multi-Unit Battery Chargers, Six-Pocket Dual-Rate 50/60Hz:

- NTN1177 90-240Vac, with 117Vac Cord and Plug
- NTN1178 90-240Vac with International 220Vac Cord and Plug
- NTN1179 90-240Vac with International 240Vac Cord Plug

Remote Speaker/Microphones

- NMN6191 *Noise-Canceling Microphone; Includes Coiled Cord Assembly, 3.5mm Earjack, and Swivel Clip
- NMN6193 *Standard Microphone; Includes Coiled Cord Assembly, 3.5mm Earjack, and Swivel Clip

Carry Accessories

- NLN6042 3" Black Belt
- NLN6349 Shoulder Carry Strap
- NLN8410 Velcro Patch Pin Attachment
- NTN7238 Leather Carry Case with Belt Loop and T-Strap for High-Capacity
- NTN7239 Leather Carry Case with Belt Loop and T-Strap for Ultra-High-Capacity
- NTN8035 Leather Carry Case with High Activity Swivel 2.5" Belt Loop and T-Strap for High-Capacity
- NTN8036 Leather Carry Case with High Activity Swivel 2.5" Belt Loop and T-Strap for Ultra-High-Capacity
- NTN8037 Leather Carry Case with High Activity Swivel 3.0" Belt Loop and T-Strap for High-Capacity
- NTN8038 Leather Carry Case with High Activity Swivel 3.0" Belt Loop and T-Strap for Ultra-High-Capacity
- NTN7247 Fabric Carry Case with Belt Loop for High- and Ultra-High-Capacity
- NTN7317 Belt Clip (Fits 2.5" Belt)
- NTN7318 Belt Clip (Fits 3.5" Belt)

* These accessories are approved as being intrinsically safe by Factory Mutual Research Corporation (FMRC). Refer to the radio label for intrinsic safety ratings and required batteries. Only the accessories and antennas noted by an asterisk (*) may be used on approved radios.

 WARNING	Substitution of components may impair the intrinsic safety of the radio.
---	---

Safety Information

9

Safety Standards

The Federal Communications Commission (FCC), has adopted a safety standard for human exposure to radio frequency electromagnetic energy emitted by FCC regulated equipment. Motorola subscribes to the same safety standard for the use of its products. Proper operation of this radio will result in user exposure substantially below FCC recommended limits:

- ◆ Do not hold the radio with the antenna very close to, or touching, exposed parts of the body, especially the face, ears, or eyes, while transmitting. Hold the radio in a vertical position with the microphone two to three inches away from the lips.
- ◆ Do not hold the transmit switch (PTT) on when not actually desiring to transmit.
- ◆ Do not allow children to play with any radio equipment containing a transmitter.
- ◆ Do not operate this equipment near electrical blasting caps or in an explosive atmosphere. Under certain conditions, radios can interfere with blasting operations. When you are in the vicinity of construction work, look for, and observe signs cautioning against radio transmission. If radio transmission is prohibited, you must not transmit until out of the area. Furthermore, you must turn off your radio to prevent any accidental transmission.
- ◆ Do not replace or charge batteries in a hazardous atmosphere. Contact sparking may occur while installing or removing batteries and cause an explosion.
- ◆ Turn radio off when removing or installing a battery.

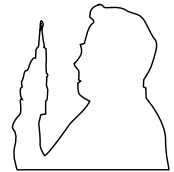

Anyone intending to use a radio in a hazardous area is advised to become familiar with the subject of intrinsic safety and with Section 70 of the National Fire Code, which is commonly referred to as Article 500 of the National Electric Code. Use of anything but factory supplied components may affect the approval and safety of the radio. Likewise, it is advised that servicing should be performed only by qualified personnel who adhere to the following Factory Mutual Research Corporation (FMRC) required warning:

 WARNING	Modification of FMRC-Approved intrinsically safe radios will negate Factory Mutual Research Corporation Approval.
---	--

Certain MTX•LS radios and batteries have been declared intrinsically safe by FMRC of Norwood, Massachusetts, for use in hazardous atmospheres. FM Approved radios are identified by attached certification labels and by matching green dots found on the bottom of radios and batteries. The intrinsically safe rating by Factory Mutual Research Corporation states that electrical equipment is incapable of releasing sufficient electrical or thermal energy, under normal or abnormal operating conditions, to cause ignition of a specific hazardous atmosphere. This means the MTX•LS radio has been thoroughly tested by Factory Mutual Research Corporation and carries its certification for operation in the hazardous atmospheres designated on the radio label. Radios must ship from the Motorola factory with the hazardous atmosphere capability and cannot be modified in the field. Failure to use the radio with the approved battery will negate the approval. MTX•LS radios that are approved by Factory Mutual Research Corporation can be used in those applications requiring reliable two way hand-held radios in the listed specific hazardous atmospheres. Motorola approved equipment and accessories, along with competitive equipment approvals, are listed in the yearly approval guide published by Factory Mutual Research Corporation. This guide can be ordered from the following address:

Training Resource Center, Publications-Order Processing Dept.
Factory Mutual Engineering and Research,
1151 Boston-Providence Turnpike
P.O. Box 9102, Norwood, MA 02062
Telephone: (617) 762-4300, extension 2152

Restrictions

Because this radio contains a transmitter, federal law prohibits unauthorized, non-licensed personnel from adjusting or maintaining it. If any operational difficulties should arise while using this product, report them to authorized service personnel as soon as possible.

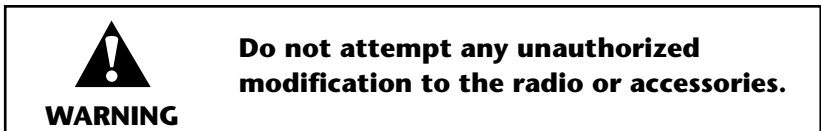

In the U.S.A., FCC Regulations prohibit this radio from transmitting in the Public Safety band (821-825MHz), except for the Mutual Aid channels.

NOTE: Operators are responsible to ensure that local regulations are met.

Airbag Warning Statement

 <p>WARNING</p>	<p>VEHICLES EQUIPPED WITH AIR BAGS An air bag inflates with great force. DO NOT place objects, including communication equipment, in the area over the air bag or in the air bag deployment area. If the communication equipment is improperly installed and the air bag inflates, this could cause serious injury.</p>
---	---

- ◆ Installation of vehicle communication equipment should be performed by a professional installer/technician qualified in the requirements for such installations. An air bag's size, shape and deployment area can vary by vehicle make, model and front compartment configuration (e.g., bench seat vs. bucket seats).
- ◆ Contact the vehicle manufacturer's corporate headquarters, if necessary, for specific air bag information for the vehicle make, model and front compartment configuration involved in your communication equipment installation.

General Information

10

Radio Care

Cleaning

Clean external surfaces of the radio with a mild detergent and a stiff, non-metallic, short-bristled brush. A suitable detergent solution may be mixed by adding one teaspoon of mild dishwashing detergent to one gallon of water (0.5% solution). Apply the detergent solution sparingly with the brush, being careful not to allow excess detergent to remain entrapped near connectors and controls or in cracks and crevices. Do not submerge the radio in the detergent solution. Dry the radio thoroughly with a soft, lint-free cloth.

Clean all battery contacts with a lint-free cloth to remove dirt, grease, or other foreign material that may prevent good electrical connections.

Handling

- ◆ Avoid physical abuse; do not pound, drop, or throw the radio unnecessarily. Do not carry the radio by the antenna.
- ◆ Avoid subjecting the radio to an excess of liquids. Never allow the radio to become submerged.
- ◆ Avoid subjecting the radio to corrosives, solvents, or spirits.



Caution

Clean the radio with the recommended solution only. Cleaning the radio with solvents or spirits may be harmful and permanently damage the radio housing.

Do not disassemble the radio in any way. Keep the connector cover in place until ready to use the accessory connector. Replace the cover immediately after the accessory has been disconnected.

Service, U.S.A. only

Proper repair and maintenance procedures will assure efficient operation and long life for this product. A Motorola maintenance agreement will provide expert service to keep this and all other communication equipment in perfect operating condition. A nationwide service organization is provided by Motorola to support maintenance services. Through its maintenance and installation program, Motorola makes available the finest service to those desiring reliable, continuous communications on a contract basis.

Motorola's Customer Service Division is the largest service organization specializing in mobile communications. It includes over 900 authorized or company-owned stations. In addition, our products are serviced throughout the world by a wide network of company or authorized independent distributor service organizations. For a contract service agreement, please contact your nearest Motorola service representative, authorized Motorola dealer, or Motorola sales representative. If you suspect a radio problem, check the following items before requesting service.

Radio Checks

- ◆ Be sure the radio is turned on and both the 16-position switch and the 3-position toggle switch are in the proper positions.
- ◆ Replace or recharge the battery. The first time a new battery is used, it should charge a minimum of 16 hours.
- ◆ Antenna must be screwed on properly; the base flush against the radio top.
- ◆ Could your radio problem be caused by accessories connected improperly?

Operating Instructions

Review your operation instructions to ensure proper radio use.

Problem(s) Not Solved

After performing suggested radio checks and reviewing your operating instructions, if your radio still exhibits a problem, review your service agreement and call the applicable Motorola service representative.

If you do not have a service agreement on your radio, contact your nearest authorized Motorola service shop for guidance toward a prompt and expedient evaluation and/or repair, or call 1-800-247-2346, extension 8615.

Express Service Plus (ESP), U.S.A. only

Express Service Plus (ESP) is an optional extended service coverage plan. ESP provides for the repair of this product, at the Motorola Factory Service Center listed in step 3, below, for a period of three years (one year warranty plus two years of extended service) from the date of shipment from the factory, or the date of delivery if purchased from an authorized Motorola two-way radio dealer. If ESP has been purchased, the serial number of this product has been registered for coverage under Express Service Plus at the depot listed in step 3, as follows.

To obtain service under Extended Service Plus:

1. Check to make sure the battery or battery charger of the unit is not defective. (Batteries and chargers are excluded from this service plan).
2. Include the following information:

Your name

Company name

Address

Telephone number

A brief description of the nature of the problem or failure (be specific)

3. Pack and ship the unit (prepaid) to:

**Motorola Factory Service Center
1318 N. Plum Grove Road
Schaumburg, IL 60173**

Express Service Plus is subject to Motorola standard terms and conditions. ESP does not include repairs which will be necessary due to damage caused by accidents, physical abuse or misuse of the product(s), acts of God, and fires. Batteries, battery chargers, and external accessories are excluded from this plan. Service under ESP is available only at the service center listed herein.

If you are unsure as to whether your radio is covered under Express Service Plus, call the depot at (708) 576-5760.

Parts Information

7:00 A.M. - 7:00 P.M. (CST) Monday - Friday (Chicago, U.S.A.)

Domestic (U.S.A.) 1-800-422-4210

1-800-826-1913 (Federal Government)

TELEX: 280127

FAX: 1-708-538-8198

FAX: 1-301-925-2690 (Federal Government)

Domestic (U.S.A.) after hours or weekends

1-800-325-4036 or 1-708-576-5111

International 1-708-576-9271

TELEX: 403305 MOTO PART SHBU UD

FAX: 1-708-576-3023 TWX: 910-693-0869

No International weekend service is available.

Glossary

Call Light

RSS programmed so that the LED will blink green to indicate that a trunking group or universal ID has been received.

Channel

Defines conventional transmit and receive frequencies and muting conditions.

DPL

Digital Private-Line; digitally coded squelch, a digital version of TPL.

Group

A base unit of LTR trunking structure. Receive and transmit IDs, as well as other various features are defined here.

LTR

Logic Trunked Radio; a registered trademark of E. F. Johnson Company.

Mode

A collection of LTR groups or conventional channels (can not have both types on one mode).

PTT

Push-To-Talk. The switch located on the side of the radio which, when pressed, causes the radio to transmit. When the PTT is released, the radio receives.

Repeater

A special, fixed two-way radio that receives and re-transmits signals in order to improve communications coverage.

RSS

Radio Service Software. Used by dealers to pre-program certain functions of your radio, such as scan lists and the Time-Out Timer.

Squelch

Muting of an audio circuit when the received signal level falls below a pre-determined value. This prevents you from having to listen to constant static on your radio.

Talkaround

The ability to “talk around” a repeater by communicating directly with another mobile or portable radio.

Time-Out Timer

A programmable function that limits the amount of time the radio can transmit (that is, the amount of time the PTT can be pressed without releasing). When this function is activated, a warning tone sounds 4 seconds before the transmitter is cut off. The Time-Out Timer can be disabled or set to a preprogrammed time value (programmed via RSS).

TPL

Tone Private-Line; Continuous Tone Coded Squelch System (CTCSS), industry standard.

Universal ID

Priority ID assigned per mode (may have none or up to 4).

OPERATING INSTRUCTIONS QUESTIONNAIRE

We believe that reports from users provide valuable information for producing quality operating instructions. Your comments and answers to the following questions will aid us in preparing manuals that contain accurate and complete information of maximum benefit to you.

In reference to Manual No. **68P81083C35-0**

MTX•LS Series Portable Radios

1. Please check all the appropriate boxes:

		Clear	Confusing	Too Detailed	Too Brief	Adequate	Complete	Incomplete	Incorrect	Not Covered in This Manual
Controls and Features	text									
	illustrations									
Operating Procedures	text									
	illustrations									
Alert Tone Explanations										
Battery Information										
Options										
Model Information										
Accessories										
General Care Information										
Other (specify)										

2. For illustrating procedures, do you prefer:
 - photographs
 - line drawings
 - no preference
3. How would you rate the overall organization of this manual?
 - excellent
 - very good
 - good
 - fair
 - poor
- 4a. If this manual has a "quick reference card," do you use it?
 - yes
 - no
- 4b. If yes, how useful is it to you?
 - extremely
 - very
 - somewhat
 - not very
5. How do you rate this manual overall?
 - excellent
 - very good
 - good
 - fair
 - poor
6. Comments/Recommendations for improving operating instructions.

From: _____

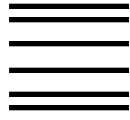

NO POSTAGE
NECESSARY
IF MAILED
IN THE
UNITED STATES

BUSINESS REPLY MAIL
FIRST CLASS MAIL PERMIT NO. 9040 FT. LAUDERDALE, FL
POSTAGE WILL BE PAID BY ADDRESSEE



MOTOROLA
Radio Products Group

Attn: Technical Publications
Room 2352
8000 W. SUNRISE BOULEVARD
FT. LAUDERDALE, FLORIDA 33322

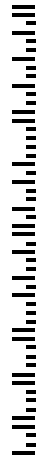
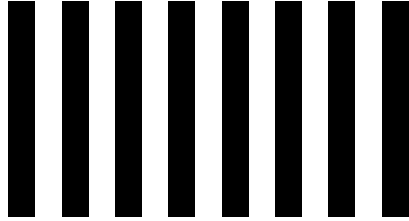

In a continuing effort to provide a better product, we need your

HELP

INITIAL PRODUCT PERFORMANCE REPORT

Please return this card **immediately** after testing or installation of your unit.

SERIAL # _____

MODEL # _____

F.O. # _____

DATE _____ TESTED BY _____

1. DID UNIT PERFORM PROPERLY? YES NO

2. IF NOT, WHAT IS NATURE OF PROBLEM? (record any reading that was off)

3. HOW WAS PROBLEM FIXED? (identify location by circuit symbol & part no.)

4. COMMENTS / SUGGESTIONS _____

5. RESPONDER'S PHONE _____ CUST. NO. _____

NAME _____

ADDRESS _____

CITY _____ STATE _____ ZIP CODE _____

CUSTOMER NAME _____

WORK ORDER NO. _____

PUBLICATIONS AVAILABLE

Manual(s) are available to support maintenance and servicing of your Motorola product. Print your name, address, and zip code **clearly** in the area provided below, and mail the card. We will send you one each of the latest up-to-date manual(s) indicated.

Theory/Troubleshooting Manual.....68P81200C15

Service Manual.....68P81200C40

NAME: _____

ADDRESS: _____

ZIP CODE: _____

PLEASE DO NOT USE POST OFFICE BOX NUMBER FOR RETURN ADDRESS.

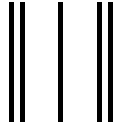

PLACE
STAMP
HERE



MOTOROLA
Radio Products Group

Attention: Bindery
8000 W. Sunrise Boulevard
Ft. Lauderdale, FL 33322

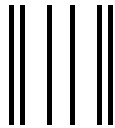

NO POSTAGE
NECESSARY
IF MAILED
IN THE
UNITED STATES

BUSINESS REPLY MAIL
FIRST CLASS MAIL PERMIT NO 4023 FT. LAUDERDALE, FL
POSTAGE WILL BE PAID BY ADDRESSEE



MOTOROLA
Radio Products Group

Attn: Director of Quality Assurance
8000 W. Sunrise Boulevard
Ft. Lauderdale, FL 33322

